

**METHOD
STATEMENT
FOR
INSTALLATION
OF FIRE
PROTECTION
SERVICES**

TABLE OF CONTENTS

<u>Contents</u>	<u>Page</u>
1.0 OBJECTIVE	1
2.0 SCOPE	
3.0 HANGLING AND STORAGE	
4.0 WORK METHODOLOGY	
4.1 Rigid Coupling	
4.2 Mechanical T Installation	
4.3 Flexible Coupling Installation	
4.4 Drop In Anchor Installation	
4.5 Pipe Hanger Installation	
4.6 Flanged Fittings Installation	
4.7 Valve with Screw Connection Installation	
4.8 Valve with Flanged End Connection Installation	
4.9 Flow Switch Installation	
4.10 Screw Fittings Installation	
4.11 Sprinkler Head (with ceiling) Installation	
4.12 Sprinkler Head (without ceiling) Installation	
4.13 Pipe Sleeve Installation	
4.14 Fire Protection Riser Pipe Installation	
4.15 Black Pipe Painting	
4.16 Black Pipe (with Undercoat) Painting	
4.17 Galvanized Pipe Painting	
4.18 Fire Pump Installation	
4.19 FE-13 System Installation	
4.20 NAF SIII System Installation	
4.21 Fire Seal installation	
4.22 Fireman Intercom System Installation	
4.23 Fire Alarm Conduits Installation	

- 5.0 HEALTH, SAFETY, SECURITY AND ENVIRONMENT
- 6.0 LIST OF ATTACHMENTS
- 7.0 INSPECTION AND TESTING
- 8.0 LIST OF APPENDICES
- 9.0 LIST OF ATTACHMENTS

METHOD STATEMENT	
Company	Title : Method Statement for Fire Protection Services Installation Page : 4 of 46
	Reference :

1.0 OBJECTIVE

This method statement is to describe s the method of which the installation of Fire Protection Services Installation is carried out for this project.

2.0 SCOPES

This procedure applies to project site, which requires Fire Protection Services installation work, which is carried out by the company.

3.0 HANDLING AND STORAGE

3.1 PRE- DELIVERY AND STORAGE PREPARATION.

- a. Prepare delivery schedule and check site conditions as well as storage capacity.
- b. Prior to delivery of Material to site, a site survey and make all necessary co-ordination with the main contractor as regards to access for the save transportation of the said material to the designated location.
- c. Coordinate with site workers responsible for the system installation.

3.2. INCOMING STORAGE AT SITE.

- a. Check model and type of material against delivery order.
- b. Check any damage during transportation.
- c. If there is any evidence of damage, an internal inspection shall be made together with supplier's representative and the Consultant. A report shall be submitted to the Consultant on completion of such inspection.
- d. Route identification and marking work shall not be started until coordinates with other Mechanical and Electrical Services.
- e. Minor deviation from the approved construction drawing and M&E drawing would be determined on site with the consent of consultant site staff.

METHOD STATEMENT	
Company	Title : Method Statement for Fire Protection Services Installation Page : 5 of 46
	Reference :

4.0 WORK METHODOLOGY

4.1 RIGID COUPLING INSTALLATION

1) Groove Pipe

Groove the pipe ends according to the manufacturer's specification.

2) Check Pipe Ends

Pipe must be free from indentations, projections or roll marks on exterior from the ends to the groove, to assure a leak tight seat from the gasket. Refer to Figure 1.

3) Check Gasket

Pipe must be free from indentations, projections or roll marks on exterior from the ends to the groove, to assure a leak tight seat from the gasket. Refer to Figure 1.

4) Install Gasket

Place gasket over pipe ends, being sure gasket lip does not overhang pipe end. Refer to Figure 3.

5) Join Pipe Ends

Align and bring 2 pipe ends together and slide gasket into position centered between the grooves on each pipe. No portion of the gasket should extend into the groove on either pipe. Refer to Figure 4.

6) Assemble Segments

Loosely assemble all segments leaving one nut and bolt off to allow for "swing-over" feature. Refer to Figure 5.

7) Apply Housing

With 1 nut and 1 bolt removed, use the "swing-over" feature to position housings over gasket and into the grooves on both pipes. Refer to Figure 6.

8) Insert Bolt

Insert the remaining bolt to allow easy tightening of the nut. Be sure track head engages into housing recess. Refer to Figure 7.

9) Tighten Nuts

METHOD STATEMENT	
Company	Title : Method Statement for Fire Protection Services Installation Page : 6 of 46
	Reference :

Tighten nuts alternately and equally maintaining metal-to-metal contact at the angle bolt pads. Tighten securely to assure a rigid joint. Refer to Figure 8.

TECHNICAL INFORMATION FOR RIGID FITTING

- Manufacturer : Victaulic
- Model : Fire Lock (Style 005)
- Material : Ductile Iron
- Size : 65mm dia. to 200mm dia.
- Approval : UL/FM/ULC

METHOD STATEMENT		
Company	Title : Method Statement for Fire Protection Services Installation	Page : 7 of 46
	Reference :	

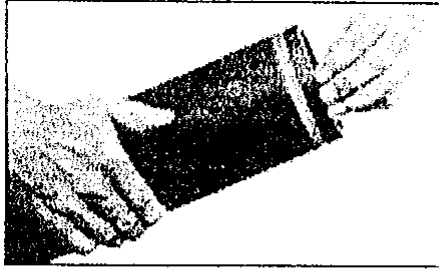

Figure 1. Check Pipe Ends

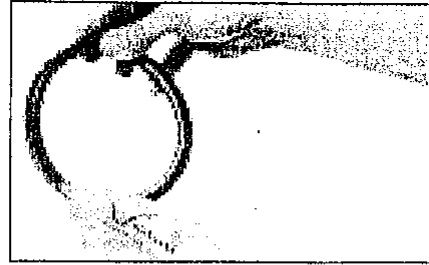

Figure 2. Check Gasket & Lubricant

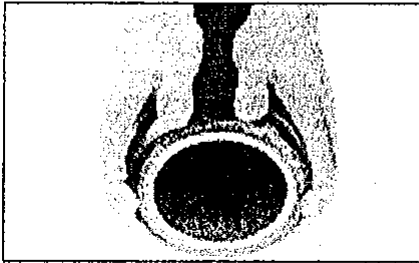

Figure 3. Install Gasket

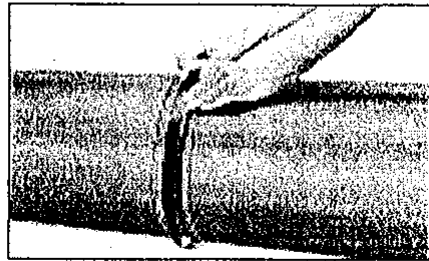

Figure 4. Join Pipe Ends



Figure 5. Assemble Segments

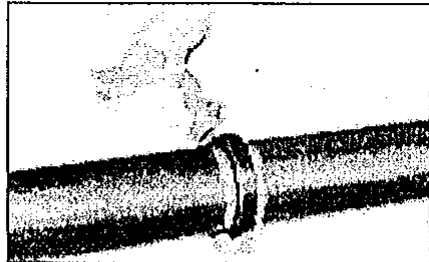

Figure 6. Apply Housing

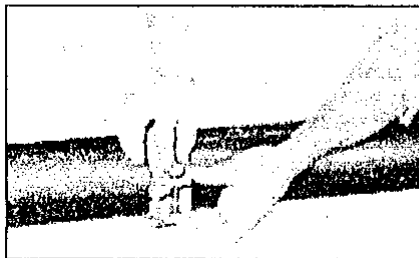

Figure 7. Insert Bolt

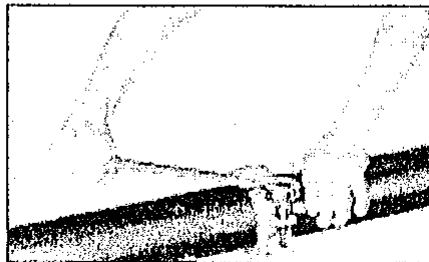

Figure 8. Tighten Nuts

METHOD STATEMENT		
Company	Title : Method Statement for Fire Protection Services Installation	Page : 8 of 46
	Reference :	

4.2 MECHANICAL-T INSTALLATION

1) Drill Hole

Drill the hole according to the manufacturer's specification. Hole size refer to appendix 1.

2) Prepare to Assembly

Remove 1 nut and bolt from housing. Loosen the other nut until it is flush with the end of the bolt. Remove the tape and lift the gasket from Mechanical-T outlet. Refer to Figure 1.

3) Check Gasket & Lubricants

Check gasket supplied to be certain it is suited for intended service. Apply a thin coat of silicone lubricant to gasket lips and outside of gasket. Refer to Figure 2.

4) Position Gasket

Reposition gasket into housing using alignment tabs on slides for proper positioning. Refer to Figure 3.

5) Position Mechanical-T

- a) **(Style 920)** Rotate the lower housing approximately 90 degree away from the upper housing. Place the upper section onto the face of the pipe in line with outlet hole. Rotate the lower section around the pipe end and close the 2 halves.
- b) **(Style 921)** Place the upper section onto the face of the pipe with the locating collar engaging into the hole. Slide U-bolt end with nut into slot, swing opposite end into other slot. Apply nut and tighten both sides evenly until finger tight.

6) Check Locating Collar

Make sure that the locating collar is in the outlet hole by rocking the upper housing in the hole. Refer to Figure 5.

7) Insert Bolt

Insert bolt in its hole and finger tighten both nuts. Be certain oval-neck of bolt engages recess in housing. Make sure that the locating collar is in the outlet hole and the positioning lugs are properly aligned.

8) Tighten Nuts

METHOD STATEMENT		
Company	Title : Method Statement for Fire Protection Services Installation	Page : 9 of 46
	Reference :	

Tighten bolt nuts uniformly until the upper housing is in complete surface contact in the gasket pocket area and the assembly is rigid.

TECHNICAL INFORMATION FOR MECHANICAL-T FITTING

- Manufacturer : Victaulic
- Model : Style 920 and Style 921
- Material : Ductile Iron
- Size : 65mm dia. to 200mm dia.
- Approval : UL/FM/ULC

METHOD STATEMENT		
Company	Title : Method Statement for Fire Protection Services Installation	Page : 10 of 46
	Reference :	



Figure 1. Prepare To Assemble



Figure 2. Check Gasket and Lubricate



3. Position Gasket in Housing

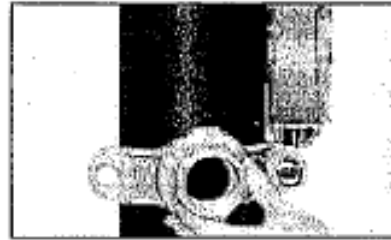

Figure 4A. Position Mechanical-T Outlet (S/920)



Figure 4B. Position Mechanical-T Outlet (S/921)



Figure 5. Check Locating Collar

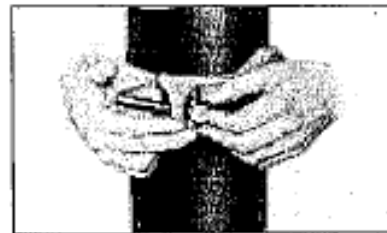

Figure 6. Insert Bolt



Figure 7. Tighten Nuts

METHOD STATEMENT		
Company	Title : Method Statement for Fire Protection Services Installation	Page : 11 of 46
	Reference :	

4.3 FLEXIBLE COUPLING INSTALLATION

1) Groove Pipe

Groove the pipe ends according to the manufacturer's specification.

2) Check Pipe Ends

Pipe must be free from indentations, projections or roll marks on exterior from the ends to the groove, to assure a leak tight seat from the gasket. Refer to Figure 1.

3) Check Gasket & Lubricant

Check gasket supplied to be certain it is suited for intended service. Apply a thin coat of silicone lubricant to gasket lips and outside of gasket. Refer to Figure 2.

4) Install Gasket

Place gasket over pipe ends, being sure gasket lip does not overhang pipe end. Refer to Figure 3.

5) Join Pipe Ends

Align and bring 2 pipe ends together and slide gasket into position centered between the grooves on each pipe. No portion of the gasket should extend into the groove on either pipe. Refer to Figure 4.

6) Apply Housing

Place housings over gasket, being sure the housing keys engage into grooves.

7) Apply Nuts

Insert nuts and apply nuts finger tight.

8) Tighten Nuts

Tighten nuts alternately and equally until housing bolt pads are firmly together metal-to-metal. Excessive nut tightening is not necessary.

METHOD STATEMENT		
Company	Title : Method Statement for Fire Protection Services Installation	Page : 12 of 46
	Reference :	

TECHNICAL INFORMATION FOR FLEXIBLE COUPLING

- Manufacturer : Victaulic
- Model : Style 75 Flexible Coupling
- Material : Ductile Iron
- Size : 65mm dia. to 200mm dia.
- Approval : UL/FM/ULC

METHOD STATEMENT		
Company	Title : Method Statement for Fire Protection Services Installation	Page : 13 of 46
	Reference :	

4.4 DROP IN ANCHOR INSTALLATION

1) Marking

Identify the actual location of the hanger based on the approved shop drawing. Mark the position for installing the drop in anchor.

2) Confirm Hole of Depth

Check the hanger size to confirm the depth of the hole to be drilled based on approved shop drawings and manufacturer's specification.

3) Drill Hole

Check the hanger size to select the right drill bit. Then drill the hole according to the manufacturer's specification on the marked position. Refer to Figure 1.

4) Cleaning

Clean the drilled hole to ensure it is free of dust. Refer to figure 2.

5) Insert drop in Anchor

Insert the drop in anchor into the hole. Refer to figure 3.

6) Hammering

Hammering down the conical plug inside the anchor with setting punch. Refer to figure 4.

7) Install Hanger Rod

Install the hanger rod into the drop in anchor. Refer to figure 5.

4.5 PIPE HANGER INSTALLATION

METHOD STATEMENT		
Company	Title : Method Statement for Fire Protection Services Installation	Page : 14 of 46
	Reference :	

1) Confirm Location

Identify the actual location of the hanger based on the approved shop drawing. Mark the position for installing the drop in anchor.

2) Install Drop in Anchor

Install drop in anchor. (Please refer to Method Statement for Drop in Anchor Installation) Refer figure 1.

3) Install Pipe

Install the pipe either by screw fitting or welding. Refer to figure 2.

4) Install Hanger Rod

Select the hanger based on the pipe size. Install the hanger rod to the drop in anchor.

5) Install Hanger

Install the hanger to the pipe and the hanger rod. Refer to figure 3.

6) Tightening

Tighten the bolts and nut that hold the hanger rod and hanger evenly.

TECHNICAL INFORMATION FOR PIPE HANGER

Company	METHOD STATEMENT	
	Title : Method Statement for Fire Protection Services Installation	Page : 15 of 46
	Reference :	

- Manufacturer : UBE Industries (Malaysia)
- Model : Ring Hanger
- Material : Mild Steel
- Finishes : Galvanized Plated
- Size : 15mm dia. to 200mm dia. pipe size

SCHEDULE OF PIPE HANGER SPACING AND ROD SIZE

Pipe Diameter (mm)	Maximum Hanger Spacing (mm)	Rod Size (mm)
12	3000	10
25	3000	10
32	3000	10
40	3000	10
50	3000	10
65	3000	10
80	3000	10
100	3000	10
150	3000	12
200	3000	12

METHOD STATEMENT		
Company	Title : Method Statement for Fire Protection Services Installation	Page : 16 of 46
	Reference :	

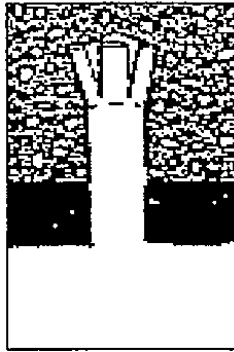

Figure

1. Install Drop in Anchor

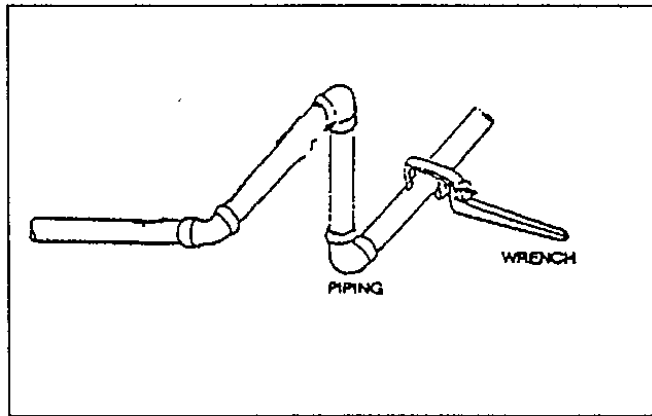

Figure

2. Install Pipe

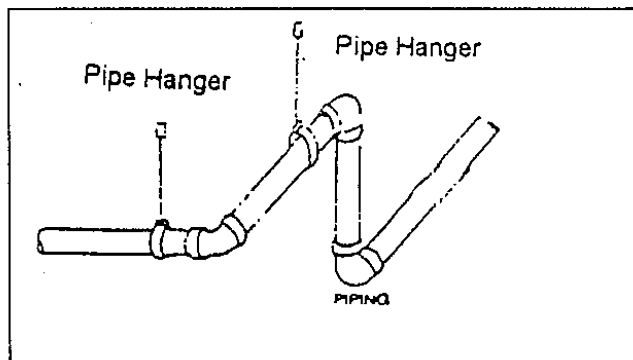

Figure

3. Install Hanger to Pipe

METHOD STATEMENT		
Company	Title : Method Statement for Fire Protection Services Installation	Page : 17 of 46
	Reference :	

4.6 **FLANGE FITTING INSTALLATION**

1) Select Flange

Check the flange size and specification according to pump size and valve size, for example Table E, Table F etc. refer to appendix 1.

2) Fabricate Pipe

Cut the pipe to the required length. Refer to figure 1.

3) Jointing

Jointing the flange to either valve or pump. (Please refer to the Method Statement for Valve with Flange End Connection Installation). Refer to figure 2.

METHOD STATEMENT		
Company	Title : Method Statement for Fire Protection Services Installation	Page : 18 of 46
	Reference :	

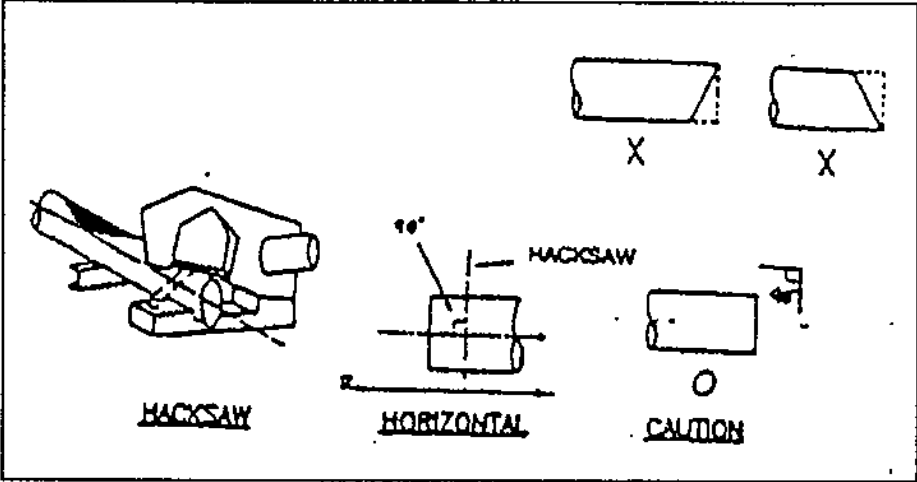

Figure

1. Marking and cut pipe

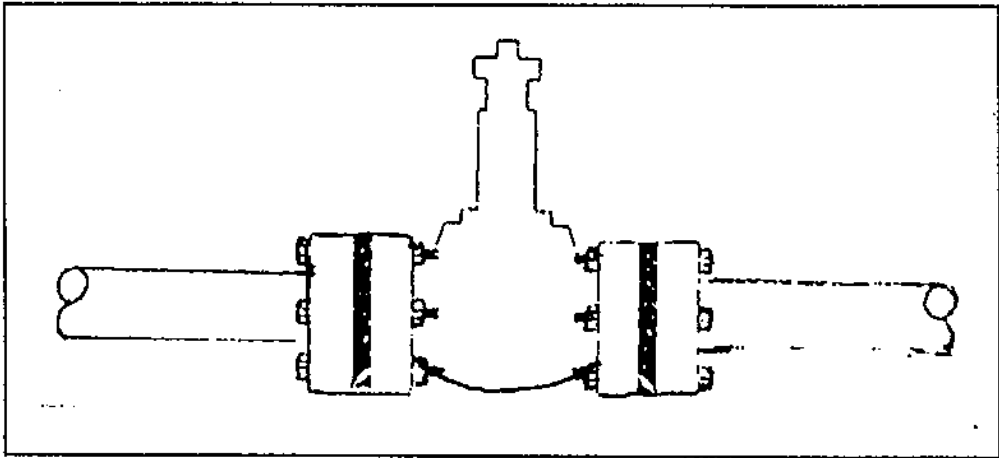

Figure

2. Jointing

METHOD STATEMENT		
Company	Title : Method Statement for Fire Protection Services Installation	Page : 19 of 46
	Reference :	

4.7 **VALVE with SCREW CONNECTION INSTALLATION**

1) Select Valve

Confirm the valve size and location based on the shop drawings. Ensure that the selected valve is screw type.

2) Fabricate Pipe

Cut the pipe to the required length and thread it accordingly. Attached the threaded table at appendix 1.

3) Positioning

Place the valve between the pipe and make sure the threads are free of dust. Refer to figure 1.

4) Jointing

Guide one of the pipe ends onto the valve's thread, slowly run pipe in clock-wise direction. Refer to the figure 2.

5) Tightening

Hold the valve firmly by a spanner on the flat nearest joint and then rotate the pipe with a plumbing wrench. Rotate the pipe until the end of the spindle operating joint. Repeat the above steps for the other pipe. Refer to figure 3.

METHOD STATEMENT		
Company	Title : Method Statement for Fire Protection Services Installation	Page : 20 of 46
	Reference :	

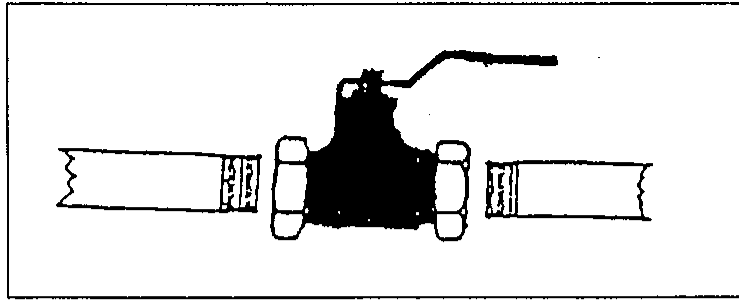

Figure
1. Positioning Valve

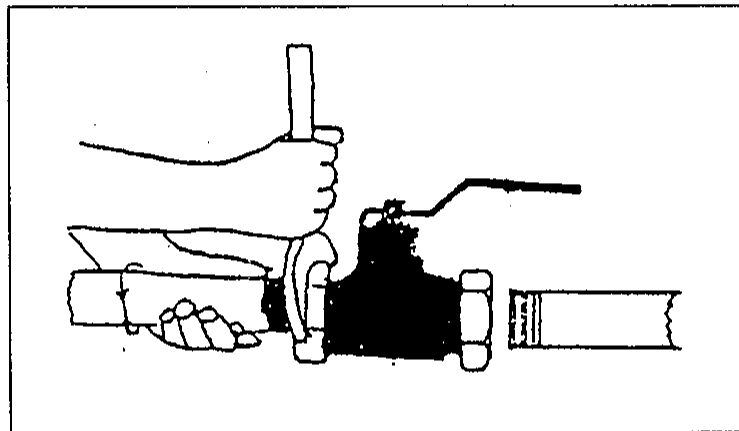

Figure
2. Jointing

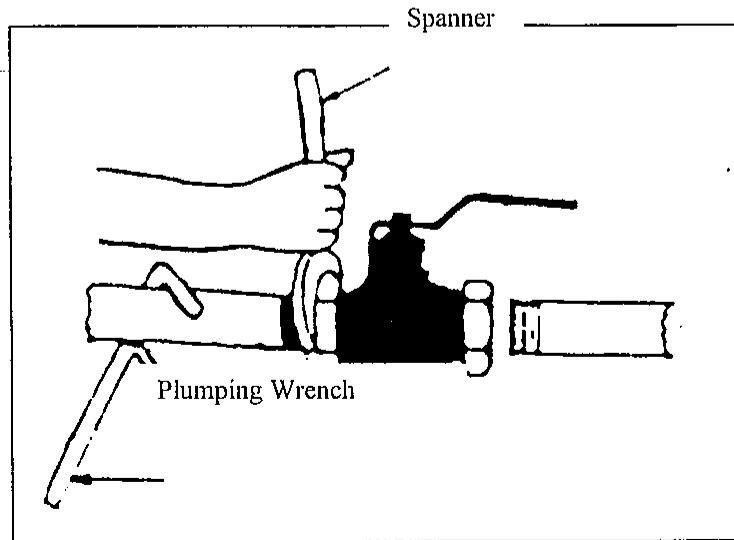

Figure
3. Tightening

METHOD STATEMENT		
Company	Title : Method Statement for Fire Protection Services Installation	Page : 21 of 46
	Reference :	

4.8 **VALVE with FLANGE END CONNECTION INSTALLATION**

1) Select Valve

Confirm the valve size and location based on the shop drawings. Ensure that the selected valve is flange type.

2) Positioning

Place the valve between the pipe flanges. Make sure the flange and adjacent pipe work are clean of dirt. Refer to figure 1.

3) Select Gasket

Select the gasket size according to the valve size and associated pipe size based on approved shop drawings so that it can match the pipe work flange. Refer to figure 2.

4) Connecting

Connect the valve with the pipe flange. The pipe flange shall be square with the associated pipeline. Refer to figure 3.

5) Tightening

When the valve is in proper position, install the bolts into the holes. Tightening the nuts one by one evenly. Repeat the above steps for the other joint. Refer to figure 4.

METHOD STATEMENT		
Company	Title : Method Statement for Fire Protection Services Installation	Page : 22 of 46
	Reference :	

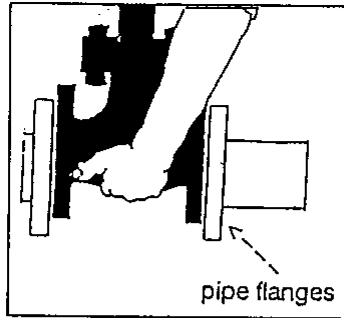

Figure 1 Positioning Valve

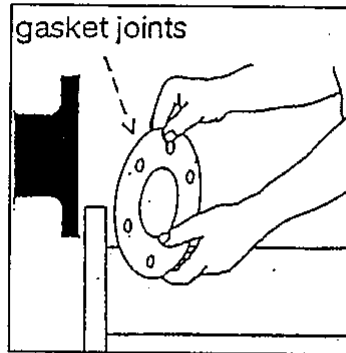

Figure 2 Check Gasket

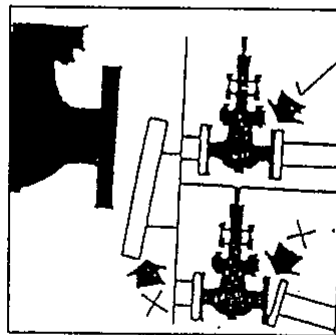

Figure 3 Connecting

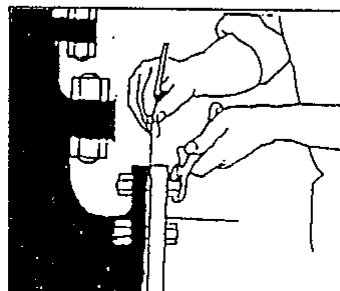

Figure 4 Tightening

Company	METHOD STATEMENT	
	Title : Method Statement for Fire Protection Services Installation	Page : 23 of 46
	Reference :	

4.9 **FLOW SWITCH INSTALLATION**

1) Select Flow Switch

Confirm the valve size and location based on the shop drawings. Ensure that the selected valve is flange type.

2) Confirm Location

Place the valve between the pipe flanges. Make sure the flange and adjacent pipe work are clean of dirt. Refer to figure 1.

3) Drill Hole

Select the gasket size according to the valve size and associated pipe size based on approved shop drawings so that it can match the pipe work flange. Refer to figure 2.

Pipe Size	Hole Size
2" to 2 ½ "	1 ¼ " + 1/8" - 1/16"
3" to 10"	2" ± 1/8"

4) Cleaning

Clean the inside pipe of all growth or other materials for a distance equal to the pipe diameter on either side of the hole.

5) Invert Vane

Roll the vane so that it may be inserted into the hole, do not bend or crease it. Insert the vanes so that the arrow on the saddle points in the direction of water flow. Refer to figure 2.

6) Tightening

Install the saddle points and tightening the nuts alternatively. The vane must not rub the inside of the pipe or bind in any way. Refer to figure 3.

METHOD STATEMENT		
Company	Title : Method Statement for Fire Protection Services Installation	Page : 24 of 46
	Reference :	

TECHNICAL INFORMATION FOR FLOW SWITCH

- Manufacturer : Potter (USA)
- Model : VSR - F
- Material : Vane
- Size : 65mm dia. to 150mm dia.
- Approval : UL/FM/ULC

METHOD STATEMENT		
Company	Title : Method Statement for Fire Protection Services Installation	Page : 25 of 46
	Reference :	

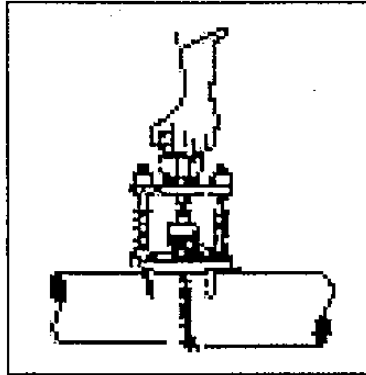

Figure 1 Drill a hole on pipe

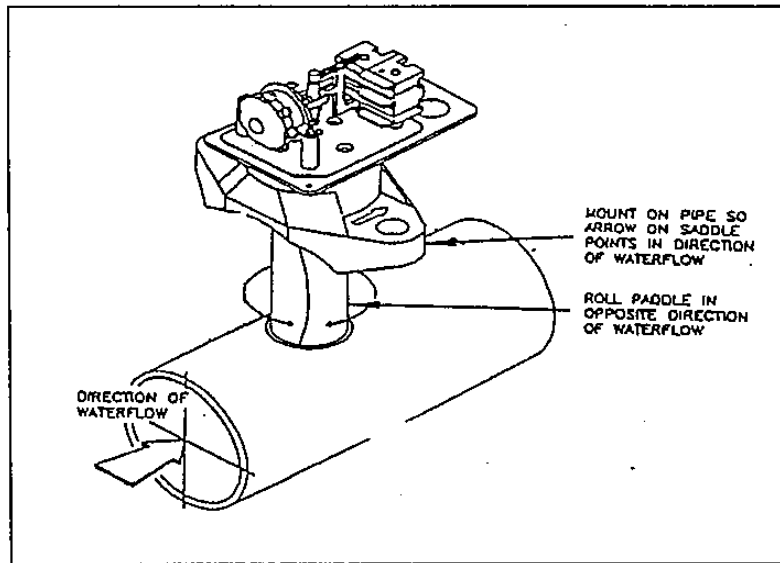

Figure 2 Insert vane

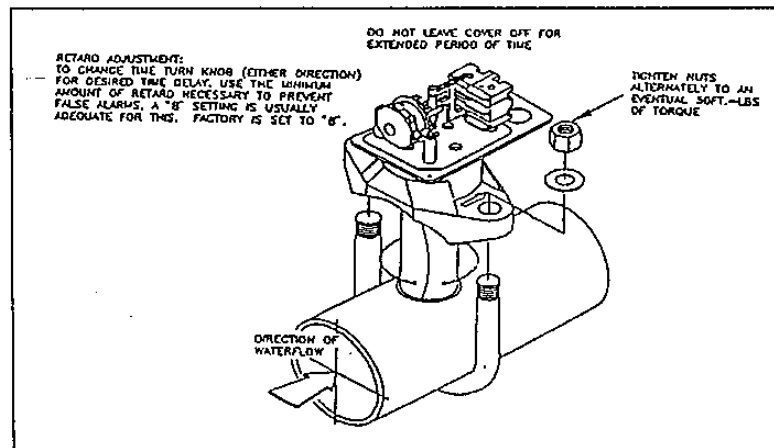

Figure 3 Tightening

METHOD STATEMENT		
Company	Title : Method Statement for Fire Protection Services Installation	Page : 26 of 46
	Reference :	

4.10 **SCREW FITTING INSTALLATION**

1) Check Pipe Length

Check the pipe length required based on the approved shop drawing.

2) Marking & Cutting

Mark the desired length on the pipe and cut it by using a hacksaw. Make sure the pipe is perpendicular to the hacksaw cut. Refer to Figure 1.

3) Threading

Place the pipe in the threading machine and thread it accordingly. Make sure the thread of the pipe is in good condition. Refer to Figure 2.

4) Wrap Teflon Tape

Remove the oil from the pipe end after the threading procedure and wrap it with Teflon tape. Refer to Figure 3.

5) Installation

Install the pipe to the screw fitting. Refer to Figure 4.

METHOD STATEMENT		
Company	Title : Method Statement for Fire Protection Services Installation	Page : 27 of 46
	Reference :	

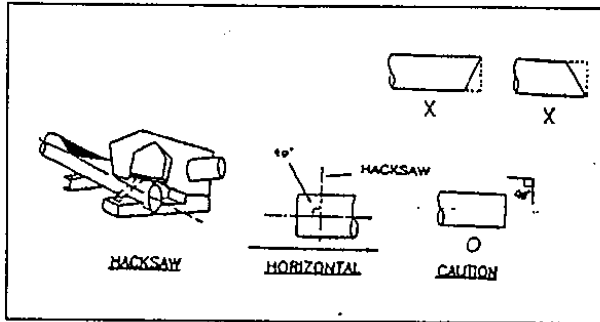

Figure 1 Marking and cutting

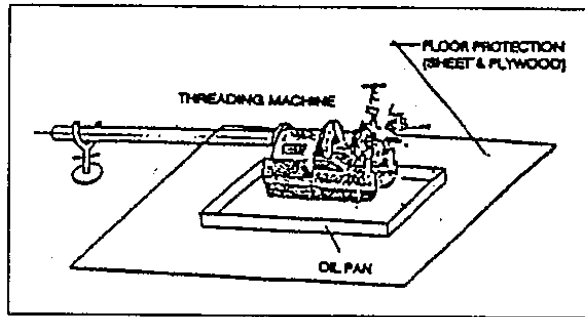

Figure 2 Threading

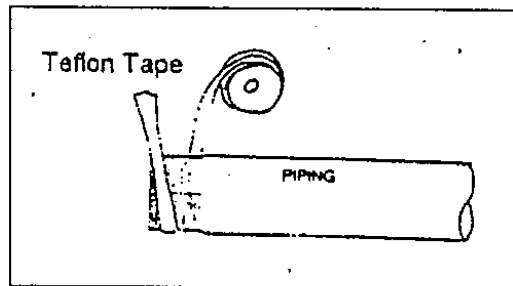

Figure 3 Wrap with Teflon Tape

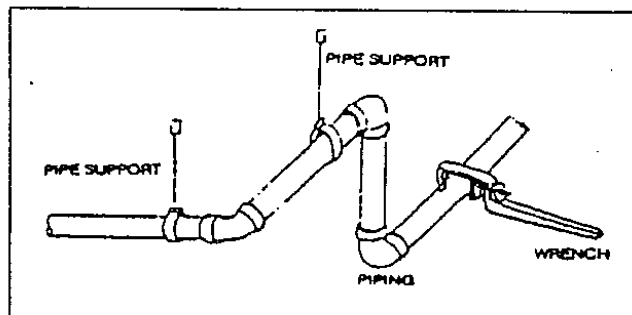

Figure 4 Installation

METHOD STATEMENT		
Company	Title : Method Statement for Fire Protection Services Installation	Page : 28 of 46
	Reference :	

4.11 **SPRINKLER HEAD with CEILING INSTALLATION**

1) Select Sprinkler Head & Confirm Location

Select the sprinkler head according to the approved materials list and ensure that the sprinkler head positions are based on the approved shop drawing.

2) Check Ceiling Tee Installation

Ensure the ceiling tee is being installed and leveled (by other).

3) Install Dropper

Install the dropper pipe to the sprinkler range pipe.

4) Cleaning

Clean the screw fitting and sprinkler tee joint to ensure they are free of dust.

5) Wrapping

Wrap the screw joint of the sprinkler head Teflon tape to prevent leaking.

6) Tightening

Install the sprinkler head rosette and sprinkler head to screw joint of the dropper pipe. Then, tighten the sprinkler head into the screw fitting by using wrench.

7) Levelling

Ensure the sprinkler head is level against the ceiling board.

METHOD STATEMENT		
Company	Title : Method Statement for Fire Protection Services Installation	Page : 29 of 46
	Reference :	

4.12 **SPRINKLER HEAD without CEILING INSTALLATION**

1) Select Sprinkler Head & Confirm Location

Select the sprinkler head according to the approved materials list and ensure that the sprinkler head position are based on the approved shop drawing.

2) Cleaning

Clean the screw fitting and sprinkler tee joint to ensure they are free of dust.

3) Wrapping

Wrapping the screw joint of the sprinkler head Teflon tape to prevent leaking.

4) Tightening

Then tightening the sprinkler head into the screw fitting by using wrench.

4.13 **PIPE SLEEVE INSTALLATION**

1) Confirm Location

Check the approved shop drawings for the actual location of the pipe sleeve to be provided.

2) Marking

Mark the location of the pipe and identify the size of pipe sleeve to be provided. *(Note : The pipe sleeve should be 1 pipe size bigger than the actual pipe running)*

3) Submit for Approval

Then, the location and size of pipe sleeve to be provided shall be submit to Consultant approval.

4) Install

Upon approval, the pipe sleeve shall be provided before the concreting.

METHOD STATEMENT	
Company	Title : Method Statement for Fire Protection Services Installation Page : 30 of 46
	Reference :

4.14 **FIRE PROTECTION RISER PIPE INSTALLATION**

PURPOSE

This method statement defines the methods and sequence to be carried out for the installation of Fire Protection Riser Pipe to ensure they are in compliance with contract requirements, technical specifications and quality management.

SCOPE

This shall cover all the Fire Protection System, i.e. Sprinkler System, wet Riser and Hose Reel System.

PROCEDURE

1) Check Location of Riser

1. Confirm the location of riser based on approved / coordinated shop drawings.
2. Check whether any opening through slabs (either box-up or pipe sleeves) is provided.
3. Check the size of the opening. If the opening size is not sufficient or opening is not provided, request permission for coring from the Main Contractor.
4. Core opening once approval is obtained.

2) Fabrication of Pipe

1. Fabricate pipes

3) Hoisting of Pipe

1. Book the Materials Hoist or Tower Crane for hoisting the pipes to the designated floors.
2. Position the pipes at the area allocated by the Main Contractor.

METHOD STATEMENT		
Company	Title : Method Statement for Fire Protection Services Installation	Page : 31 of 46
	Reference :	

4) Install Riser Pipe

1. Confirm the location of riser based on approved / coordinated shop drawings.
2. Lower down the pipe off any unwanted materials and rubbish from the riser shaft.
3. If box opening is provided, slip a piece of pipe sleeve onto the pipe.
4. Coupled the pipe with previously installed pipe with a flexible coupling. (Please refer to Method Statement for the installation method of flexible coupling).
5. Pull upwards the newly installed pipe using the chain block. This is to allow pipe movement during the building shrinkage.
6. Align the pipe vertically with spirit level.

5) Install Riser Pipe Bracket

1. Once the pipe has been aligned, install the pipe bracket to support the riser pipe.
2. If box opening is provided, install temporary bracket to the pipe.
3. Cast the opening and ensure the pipe sleeves are installed prior to casting.
4. Once the concrete has cured, dismantled the temporary bracket and replace it with a permanent bracket.

6) Install Fire Barrier

1. Install Rock Wool into the gap between the riser pipe and the pipe sleeve as per contract requirement. The Rock Wool will act as fire barrier in the case of fire.

Company	METHOD STATEMENT	
	Title : Method Statement for Fire Protection Services Installation	Page : 32 of 46
	Reference :	

FLOW CHART FOR RISER PIPES INSTALLATION

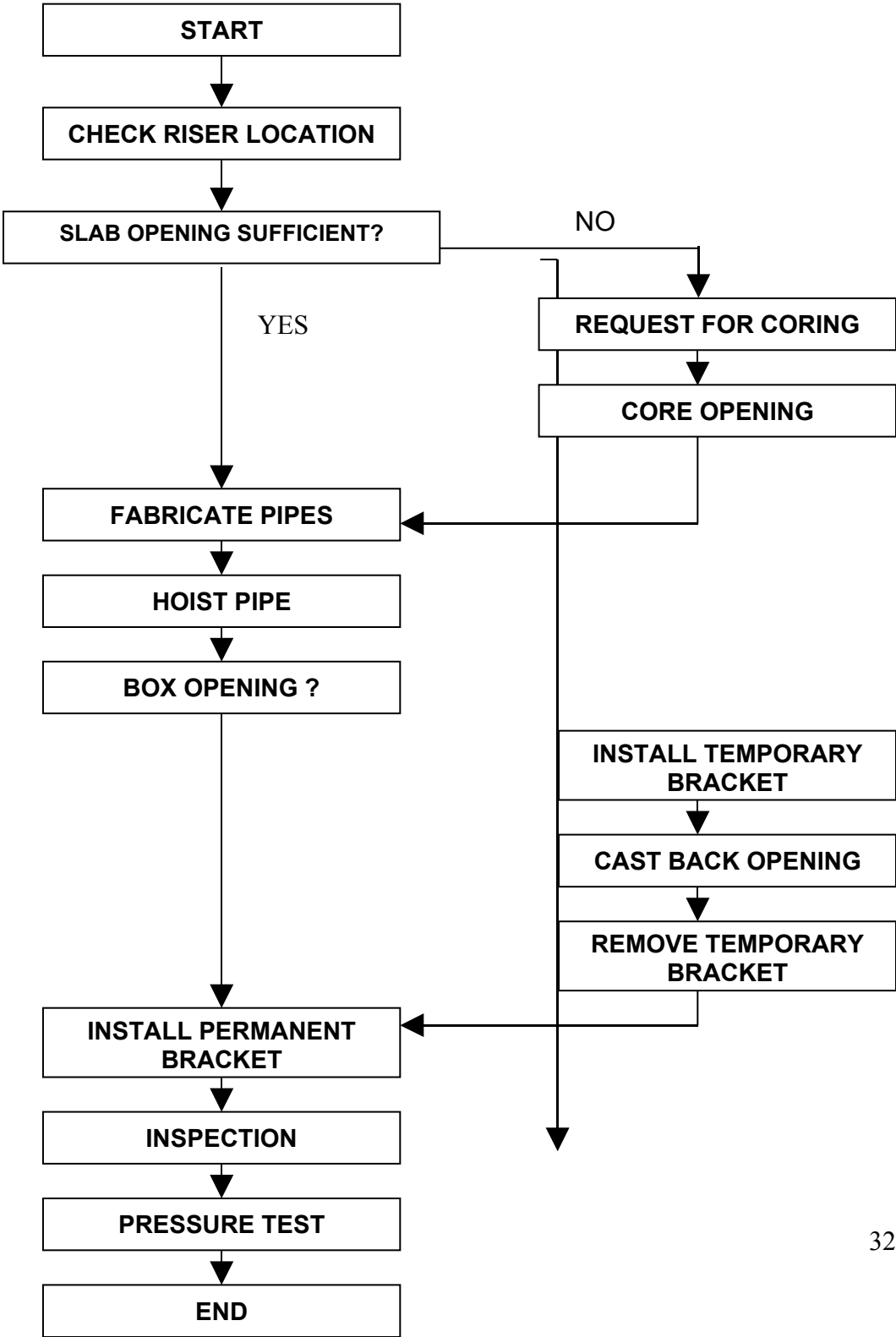

METHOD STATEMENT		
Company	Title : Method Statement for Fire Protection Services Installation	Page : 33 of 46
	Reference :	

4.15 BLACK PIPE PAINTING

1) Clean the Black Pipe

Clean the black pipe with cotton rag to remove any dust or grease on the pipes.

2) Paint the Pipe with Red Oxide

After cleaning, paint the black pipes with 1 layer undercoat of Red Oxide Primer. Please ensure both sides (top & bottom) are painted evenly.

3) Wait for Dry

Put the painted pipes in a good ventilation condition for 24 hours for the paint to dry.

4) Paint with Finish Coat

After the paint is dried, then paint the pipes with 1 layer of finish coat (Nippon 9000, Flamengo 1420). Please ensure both sides (top & bottom) are painted evenly.

5) Install the Pipe

After the finish coat dries, install the pipes.

6) Paint Final Layer

After installation, paint the final layer of paint (Nippon 9000, Flamengo 1420) to the installed pipes. Please ensure both sides (top & bottom) are painted evenly.

4.16 BLACK PIPE with UNDERCOAT PAINTING

1) Clean the Undercoat Black Pipe

Clean the undercoat black pipes with cotton rag to remove any dust on the pipes.

METHOD STATEMENT		
Company	Title : Method Statement for Fire Protection Services Installation	Page : 34 of 46
	Reference :	

2) Paint with Finish Coat

After cleaning, paint the black pipes with 1 layer finish coat (Nippon 9000, Flamengo 1420) on both sides of pipes.

3) Install the Pipe

After the finish coat dry, install the pipes.

4) Paint Final Layer

After installation, paint the final layer of paint (Nippon 9000, Flamengo 1420) to installed pipes. Please

4.17 GALVANIAED PIPE PAINTING

1) Clean the Galvanized Pipe

Clean the galvanized pipe with cotton rag to remove any dust or grease on the pipes.

2) Paint the Pipes with Zinc Chromide

After cleaning, paint the galvanized pipes with 1 layer undercoat of Zinc Chromide Primer. Please ensure both sides (top & bottom) are painted evenly.

3) Wait for Dry

Put the painted pipes in a good ventilation condition for 24 hours for the paint dry.

4) Paint with Finish Coat

After the paint dried, then paint the pipes with 1 layer of finish coat (Nippon 9000, Flamengo 1420). Please ensure both sides (top & bottom) are painted evenly.

5) Install the Pipes

After the finish coat dry, install the pipes.

6) Paint Final Layer

After installation, paint the final layer of paint (Nippon 9000, Flamengo 1420) to the installed pipes. Please ensure both sides are painted evenly.

METHOD STATEMENT		
Company	Title : Method Statement for Fire Protection Services Installation	Page : 35 of 46
	Reference :	

4.18 FIRE PUMP INSTALLATION

1) Pump Plinth

Ensure pump plinth provided according to the specification and clearly status in the drawing.

2) Inspect Inertia Block

Inspect inertia block deliver and ensure it according to the specification.

3) Inspect Spring Isolator

Inspect spring isolator deliver. Ensure it is according to the specification.

4) Fire Pump Inspection

Ensure all the fire pumps deliver are according to the specification. Each pump deliver to site will be provide with a copy of approved test certificate.

5) Fire Pump Installation

Install the fire pump according to the procedures below:

- a) Provide the pump plinth
- b) Install the Spring Isolator according to the mounting with the inertia block.
- c) Mount the inertia block on top of the spring isolator.
- d) After that mount the fire pump base on top of the inertia block.
- e) Check all seal, glands and pipeline for leaks.
- f) Check all pump bearings and lubricate with oil or grease as necessary.
- g) Check the alignment and condition of all rubber coupling between pumps and drive motors.
- h) Check all bolts and nuts for tightness and tighten as necessary.

Company	METHOD STATEMENT	
	Title : Method Statement for Fire Protection Services Installation	Page : 36 of 46
	Reference :	

4.19 FE 13 SYSTEM INSTALLATION

1) Material Inspection

Inspect all the materials deliver for install the FE 13 system are following the specification.

2) Inspect Piping Installation

Ensure all the piping install in the FE 13 system are following the drawing. Ensure that pipe brackets/hanger are installed every 3 meter.

3) Insert Wiring Installation

Inspect all the surface conduiting and wiring install in the FE 13 system protected rooms are according to the specification and approve drawing.

4) FE 13 Cylinder Installation

Install the FE 13 cylinder according to the detail FE 13 system installation in the approve drawing. Ensure each of the cylinder are fully charged.

5) FE 13 Panel Installation

Ensure the FE 13 panel and key switch are install according to the FE 13 system layout in that room. Test the key switch. Repeat the test for 5 times.

6) Testing & Commissioning

After completed all the installation, clean out the internal surface of pipework by purging air. Ensure that the system is working by doing the internal testing.

METHOD STATEMENT		
Company	Title : Method Statement for Fire Protection Services Installation	Page : 37 of 46
	Reference :	

4.20 NAF SIII SYSTEM INSTALLATION

1) Material Inspection

Inspect all the materials deliver for install the NAF SIII system are following the specification.

2) Inspect Piping Installation

Ensure all the piping install in the NAF SIII system are following the drawing. Ensure that pipe brackets/hanger are installed every 3 meter.

3) Insert Wiring Installation

Inspect all the surface conduit and wiring install in the NAF SIII system protected rooms are according to the specification and approve drawing.

4) NAF SIII Cylinder Installation

Install the NAF SIII cylinder according to the detail NAF SIII system installation in the approve drawing. Ensure each of the cylinder are fully charged.

5) NAF SIII Panel Installation

Ensure the NAF SIII panel and key switch are install according to the NAF SIII system layout in that room. Test the key switch. Repeat the test for 5 times.

6) Testing & Commissioning

After completed all the installation, clean out the internal surface of pipework by purging air. Ensure that the system is working by doing the internal testing.

METHOD STATEMENT		
Company	Title : Method Statement for Fire Protection Services Installation	Page : 38 of 46
	Reference :	

4.21 FIRE SEAL INSTALLATION

1) Installed Pipe Sleeve

Install pipe sleeve with radius 25mm bigger than fire protection pipe.

2) Inspect Pipe & Sleeve

Ensure pipe sleeve or galvanized sheet are installed with a proper gap spacing.

3) Insert Rockwool

Insert Rockwool to the center area in between sleeve and pipe and create a tight bond.

4) Apply Sealant

Apply fire sealant to the front gap of pipe sleeve. Ensure minimum sealant penetration depth should not less than 12mm.

5) Touch-Up

Ensure the fire sealant have filled all the visible gap and make a smooth surface finishes.

6) Indicator

Apply sticker to the pipe sleeve to indicate location, type of services and personal involved in the above works.

Company	METHOD STATEMENT	
	Title : Method Statement for Fire Protection Services Installation	Page : 39 of 46
	Reference :	

4.22 FIREMAN INTERCOM SYSTEMS INSTALLATION

OBJECTIVE

This method statement is to ensure the contractor to carry out work done according the specification the specification approved by consultant.

SCOPE

The contractor shall supply and install in accordance with the specification of material and workmanship, the fireman intercom systems, underground and aboveground pipe work and electrical work.

REFERENCE

- Catalogue
- Specification
- Drawing

RESOURCES

1) Material

Item	Description	Manufacturer (brand)
1.0	Fireman Intercom System	Mictron 8

Company	METHOD STATEMENT	
	Title : Method Statement for Fire Protection Services Installation	Page : 40 of 46
	Reference :	

2) Machinery Tool Equipment

Item	Description	Manufacturer (brand)
1.0	Testing & Commissioning Systems	Multi Meter

3) Manpower

No.	Designation	No. Of Personal

HANDLING & STORAGE

The contractor shall supply and install in accordance with the specification of material and workmanship, the fireman intercom systems, underground and aboveground pipe work and electrical work.

WORK METHODOLOGY

1) Procedures

- a) Wiring installation work procedure is as the following;
 - i) The preparation of wiring installation working drawing, technical data catalog are to be in conducted simultaneously after the finalization and approval of design drawing.
 - ii) After the approval working drawing and technical data catalogs, the contractor shall proceeds with the procurement of all related equipment and materials for wiring installation work.

- b) Installation of the remote station box
 - i) Remote Station box should be installed at 1800mm height from the finished floor level at escape staircases, lift motor room, gen-set room of fire safe lobby.

METHOD STATEMENT		
Company	Title : Method Statement for Fire Protection Services Installation	Page : 41 of 46
	Reference :	

INTRODCUTION

Microprocessor based Fireman Intercom System

The fireman intercom system is designed to be used by fireman for two-way communication during fire situation or emergency.

- 1) The system consist of 2 sections;
 - a) Main Fireman Intercom Panel (MFIP).
 - i) To be situated at the Fire Control Room
 - ii) This is command center where all calling and receiving of Remote Fireman Intercom Stations (RFIS) are monitored and controlled. All the data (calling and receiving signals) are processed into audio and visual.
 - iii) The MFIP consists of the following;
 - LED indicators
 - An audible warning device (buzzer)
 - A DC Voltmeter
 - A 16 x 1 character LCD (Liquid Crystal Display) for text display
 - An operator keyboard for command entry
 - Master Handset
 - Intercom Status Panel indicating the RFIS's zone
 - b) Remote Fireman Intercom Stations (RFIS)
 - i) To be situated at fire escape routes, such as escape staircase and fire safe lobbies.
 - ii) It consists of red colour handset complete with a dynamic receiver and condenser microphone transmitter. The handset is housed red metal cabinet with glass front panel, a break glass and key operated door.
 - iii) Calling and fault condition of all RFIS are monitored at the MFIP.
 - c) Remote Telephone Terminal Unit (RTTU)

METHOD STATEMENT		
Company	Title : Method Statement for Fire Protection Services Installation	Page : 42 of 46
	Reference :	

- i) To be situated at any of the suitable area, i.e. telephone or electrical riser.
 - ii) It consist of red color box complete with zone card termination card.
 - iii) One RTTU can be linked to a maximum of 10 RFIS per set.
- 2) All the RFIS are to be terminated to the RTTU by 1 pair of PVC cable 1.5mm-sq each.
 - 3) Wiring from the RTTU (Remote Telephone Terminal Unit) to the Main Fireman Intercom Panel are:
 - a) 1 pair twisted and screened (5.4mm²) for data transmission.
 - b) 1 pair RVC cable (2.5mm²) for speech line.
 - c) 1 pair PVC cable (2.5mm²) for power supply.

TESTING & COMMISSIONING PROCEDURES

- 1) Minimum of two people are required for the testing. One stationed at the Fireman Intercom Panel and the other at any chosen Remote Fireman Intercom Station to actuate calls.
- 2) Check all indicating light on the Main Fireman Intercom panel console are in good condition.
- 3) Calling from the master handset to remote intercom station;
 - a) Pick-up the master handset, key-in the remote station's zone number at the keypad. (Example : Zone 12. Press 'Call' Key, followed by '12' and enter key).
 - b) Led at the remote handset box will light up Check the correct remote station at the zone.
 - c) Open the remote handset box, pick-up the handset. Two-way communication should establish.

METHOD STATEMENT		
Company	Title : Method Statement for Fire Protection Services Installation	Page : 43 of 46
	Reference :	

- 4) Calling from any remote intercom station to the Main Fireman Intercom panel;
 - a) Open the remote handset station box and pick up the handset, call led at the MFIP should blink and buzzer ring continuously.
 - b) Check the correct zone's calling at the Main Fireman Intercom Panel.
 - c) To establish the call. Pick up the master handset.
- 5) Conference call or party lines can be generated from master handset or remote stations – Maximum of 9 remote fireman intercom + 1 master handset can communicate simultaneously.
 - a) Refer to 'CALL' procedure (8.3 or 8.4)
 - b) During Conferencing, the master panel can terminate any calls of the remote station by pressing the 'CUT' key.
 - c) The master panel can also establish new outgoing or incoming calls by following the 'CALL procedures' and the first received call will be cut-off.
- 6) Reset the system and return it to normal position.

ATTACHMENT

- 1) Fireman Intercom – Installation & termination at Remote Fireman Intercom Handset.
- 2) Installation of Remote Fireman Intercom Box
- 3) Checklist of Testing & Commissioning – Fireman Intercom System.

METHOD STATEMENT		
Company	Title : Method Statement for Fire Protection Services Installation	Page : 44 of 46
	Reference :	

CONDUIT INSTALLATION

- 1) MEASUREMENT / LOCATION OF G.I. CONDUIT AND MARKING OF CONDUIT ROUTE.
 - a) Site supervisor will study and counter check the proposed locations of the conduit as shown on the shop drawing. Ensure proper coordination with the Main Contractor and other trades to optimize the space allocation and proper conduits management.
 - b) Site supervisor will measure the length of G.I. conduit required for installation at site and instruct the workers to prepare these conduits. Installation will be carried out in a planned and timely fashion so as not to delay works by other trades.
 - c) For horizontal installation of conduits, straight lines are marked by using string coated with white powder, tied to the nails at both ends. Ensures appropriate string tension by plucking and releasing the string before

METHOD STATEMENT		
Company	Title : Method Statement for Fire Protection Services Installation	Page : 45 of 46
	Reference :	

drawing the straight line. Repeat the steps above for vertical surface installation.

2) FIXING OF SURFACE G.I. CONDUIT

- a) After dismantling the strings and the nails, drill holes along the white lines. Insert the drop-in anchor bolt into the holes before installing the rods.
- b) Clip the G.I. conduits to the rods by using fasteners.
- c) If necessary, the G.I. conduit will be cut to length required and threaded. Threading will be process by stocks and dies. Rotate the stocks and dies two and a half turns in a clockwise direction and the in a counter clockwise direction, to clear away the accumulated swart. This will enable the tread to be cut cleanly and efficiently without fear of stripping. Once completed, file across the leading edge of the thread and reamer the inner periphery. This prevents cable snagging on burred edges.
- d) Conduit sockets complete with thread joint two length of conduits. In case of crossing or ending or at 'T' junction area, cross-boxes, "Tee" boxes, "Trough" boxed are normally used to link up conduit pipes.
- e) As soon as the conduits are fixed, site supervisor will check and inspect the site to ensure that installations are according to the shop drawings. A formal request will be extended to the Resident Engineer.

3) STANDARD AND CERTIFICATION

- a) Ensure that the capacities of trunkings and conduits provided are adequate to cater all wirings with a minimum spare space of 40%.

4) METHOD OF FIXING OF CONCEALED G.I CONDUITS

- a) Place the conduits between the two layers of slab rebar or behind the column rebars from dropper to socket outlet points.
- b) Ensure that conduits, inspection boxes, back boxes and all other accessories used are rigidly secured to the rebar and all joints are firmly tightened before concreting.

METHOD STATEMENT		
Company	Title : Method Statement for Fire Protection Services Installation	Page : 46 of 46
	Reference :	

c) Site supervisor must ensure that preventive measures are taken to keep concrete and unwanted materials from getting into the conduit by temporarily sealing off the open-ended conduits with tape.

5) METHOD OF FIXING THREADED CONDUIT AT ENTRIES INTO FAS PANEL

6) METHOD OF FIXING CONDUIT INTO CIRCULAR BOX

7) MAXIMUM ALLOWANCE SPACING BETWEEN TWO INSPECTION BOXES OR CIRCULAR BOXES SHALL NOT BE MORE THAN 9M STRAIGHT RUN.

8) BENDING OF CONDUIT

9) SUPPLEMENTARY SUPPORT AND SPACING OF SUPPORT FOR CONDUITS